

Power Ring Film Capacitor 5 μ F, 8,000Vdc

The 775D505980-104 Power Ring is a 8,000Vdc, 5 μ F high voltage pulse capacitor.



Electrical Specifications

Part #: 775D505980-104

Capacitance/Tolerance: 5 μ F \pm 10%

DC Voltage Rating: 8,000Vdc

NOTE: This capacitor is specifically designed to withstand repetitive pulse discharges at high pulse currents with longer life than exhibited by more typical metallized High Voltage film capacitors. However, this capacitor is not recommended for applications requiring continuous voltage (constant charge) unless de-rated to 4,000Vdc Maximum. For a technical explanation and further information on the intended uses for this design please contact Advanced Conversion engineering.

Dielectric/Construction: Patented pulse technology Metallized Polypropylene film. Series-section design, non-inductively wound.

Dielectric Withstand Voltage: Units 100% tested at DC potential of 9,000Vdc for two minutes at 25°C.

Peak-to-Peak Voltage: 10,000 V Max

When operated at this peak-to-peak voltage the capacitor can be expected to withstand \sim 5,000 discharges.

Further reducing this value to 7,500 V peak-to-peak will increase discharge life on the order of 10 times.

Further reducing this value to 5,600 V peak-to-peak will increase this discharge life more than 1,000 times.

Reducing the Q of the discharge circuit will improve shot life for all cases. End of life for the above estimates is 10% capacitance reduction.

Insulation resistance: 20,000 M Ω Min at +25°C

ESR @ 10 kHz: < 1.6 m Ω Min at +25°C, typical

ESL: \sim 50 nH, minimum inductance connection. The actual capacitor loop inductance will depend on the application interconnect design.

Operating Temperature: -40°C to +85°C

Peak Current Rating: 10,000 Amps repetitive

Mechanical Specifications

Diameter: 4.70" (119.7 mm)
Height: 3.35" (85 mm)
Core: Hollow phenolic core with 1.0" I.D. Meets UL-94HB Specs.
Terminals: Tin plated copper strap, 1/16" thick by 1" wide.
Encapsulation: Outer tape wrap of flame retardant polyester tape (meets UL510 specifications). Potted with white epoxy (meets UL94V-0 specs).

Mechanical Mounting: If possible mounting of this unit using the core will help to provide stress relief for the terminals.

Marking:
 APCS company identification
 775D104 "short form" part number
 5 μ F \pm 10% Capacitance value and tolerance
 8,000Vdc DC voltage rating
 yyww-lot#-unit Serial number (date code, lot number, unit number)

Layout Details:

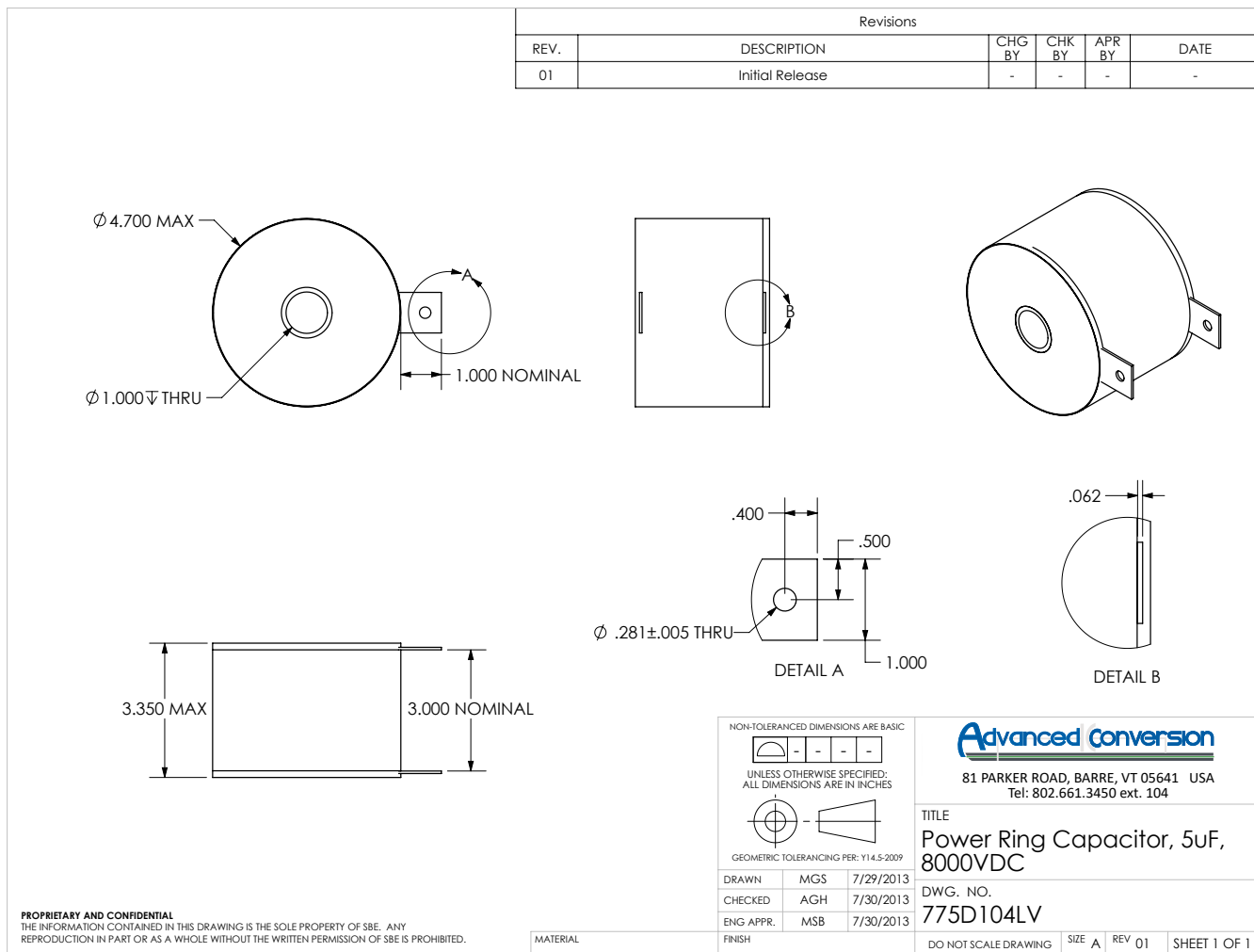

Contact Advanced Conversion to discuss your specific requirements.

Advanced Conversion reserves the right to amend design data