

- MOSFET Output
- Low On-State Resistance
- High Current Ratings
- Panel Mount

DC output relays feature MOSFET technology for low on-state resistance, assuring easy paralleling and switching capabilities to 100 amps at 60 Vdc. Lower current models are also available to 500 Vdc. All models come in Crydom's standard panel-mount package.

Manufactured in Crydom's ISO 9001 Certified facility for optimum product performance and reliability.

### OUTPUT SPECIFICATIONS ①

MODEL NUMBERS	D06D60	D06D80	D06D100
Operating Voltage Range [Vdc]	0-60	0-60	0-60
Max. Load Current ③ [A dc]	60	80	100
Min. Load Current [mA]	5	5	5
Max. Surge Current, [A dc] (10msec)	180	220	270
Max. On-State Voltage Drop @ Rated Current [Vdc]	0.6	0.7	0.5
Thermal Resistance Junction to Case ( $R_{\theta JC}$ ) [C/W]	0.6	0.47	0.32
Max On-state Resistance @ Rated Current ( $R_{DS-ON}$ ) [Ohms]	.010	.008	.005
Max. Off-State Leakage Current @ Rated Voltage [mA]	0.1	0.2	0.3
Max. Turn-On Time [ $\mu$ sec]	300	300	300
Max. Turn-Off Time [msec]	1.0	1.0	1.0

### INPUT SPECIFICATIONS ①

### DC CONTROL

Control Voltage Range	3.5-32 Vdc
Maximum Turn-On Voltage	3.5 Vdc
Minimum Turn-Off Voltage	1.0 Vdc
Nominal Input Impedance	See Note 4
Maximum Input Current	1.6 mA (5 Vdc), 28 mA (32 Vdc) ④

### GENERAL NOTES

- ① All parameters at 25° C unless otherwise specified.
- ② Dielectric strength and insulation resistance are measured between input and output.
- ③ Heat sinking required, for derating curves see page 2.
- ④ Input circuitry incorporates active current limiter.

© 2005 CRYDOM CORP, Specifications subject to change without notice.

## GENERAL SPECIFICATIONS

Dielectric Strength 60Hz	2500 Vrms
Insulation Resistance (Min.) @ 500 Vdc	10 <sup>9</sup> Ohm
Max. Capacitance Input/Output	50 pF
Ambient Operating Temperature Range	-30 to 80°C
Ambient Storage Temperature Range	-40 to 125°C

## MECHANICAL SPECIFICATIONS

Weight: (typical)	3.0 oz. (86.5g)
Encapsulation:	Thermally Conductive Epoxy
Terminals:	Screws and Saddle Clamps Furnished, Unmounted

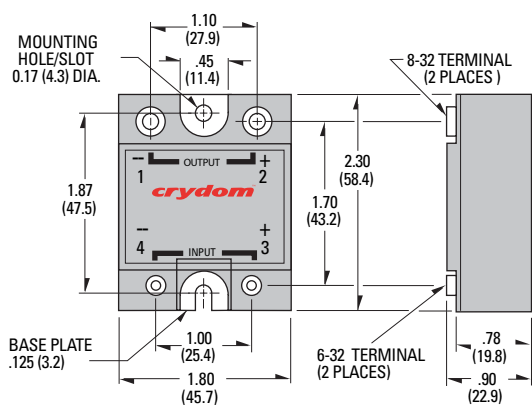

All dimensions are in inches (millimeters)

Screw Torque Requirements: 6-32 Screws - 10 in./lbs., 8-32 and 10-32 Screws - 20 in./lbs. (Screws dry without grease.)

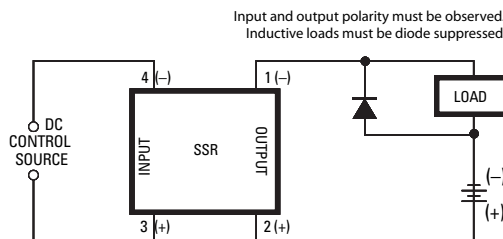

## Transient Protection

All loads are inductive, even ones that are not so labeled. An inductive load will produce harmful transient voltages when it is turned off. The more perfect the switch, the larger the transient voltages; the MOSFET output is so nearly an ideal switch that the transient voltages produced by seemingly "non-inductive" loads can cause damage if not suppressed. Diodes should be fast recovery type with PIV rated greater than supply voltage.

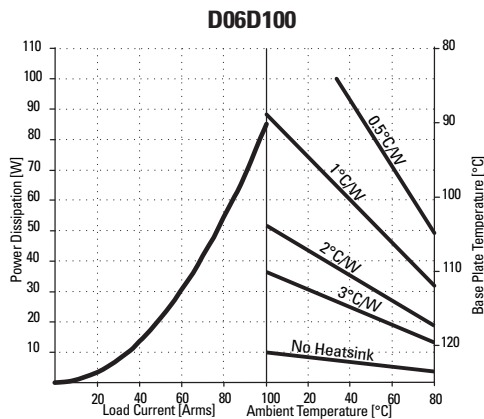
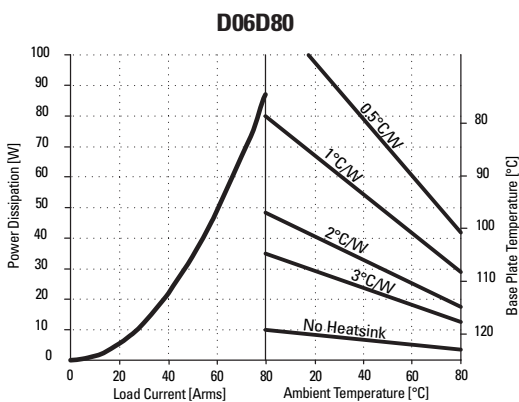
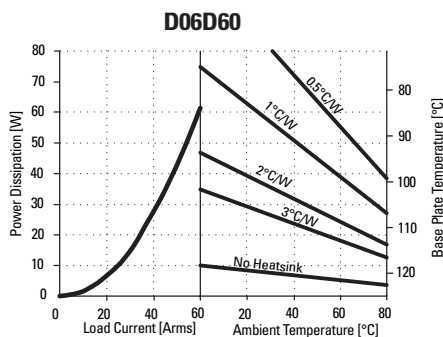

© 2005 CRYDOM CORP, Specifications subject to change without notice.