

Application Note

SSY0135 - RS232 (MICRO-50) Signal Conditioner Operating Instructions

The following Application Note details the process for connecting an .SH. Series (Ceramic) Electrolytic Tilt Sensor to the SSY0135-XX Signal Conditioning Module, and the communication protocol. The .XX at the end of the part number will denote the actual type sensor used.

General Specifications

Resolution	12 bits
Current supply	5 mA @ 12VDC
Stability over temperature	+/- 2bits
Temperature resolution	1 Deg Celsius
Operating temperature	-20C + 70C
Response Time	25 ms
Clock Speed	10Mhz

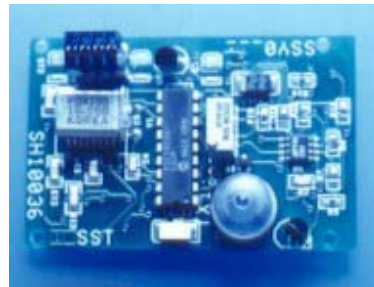

Sensor Connections

The sensor leads should be soldered to the circuit board in the following manner.

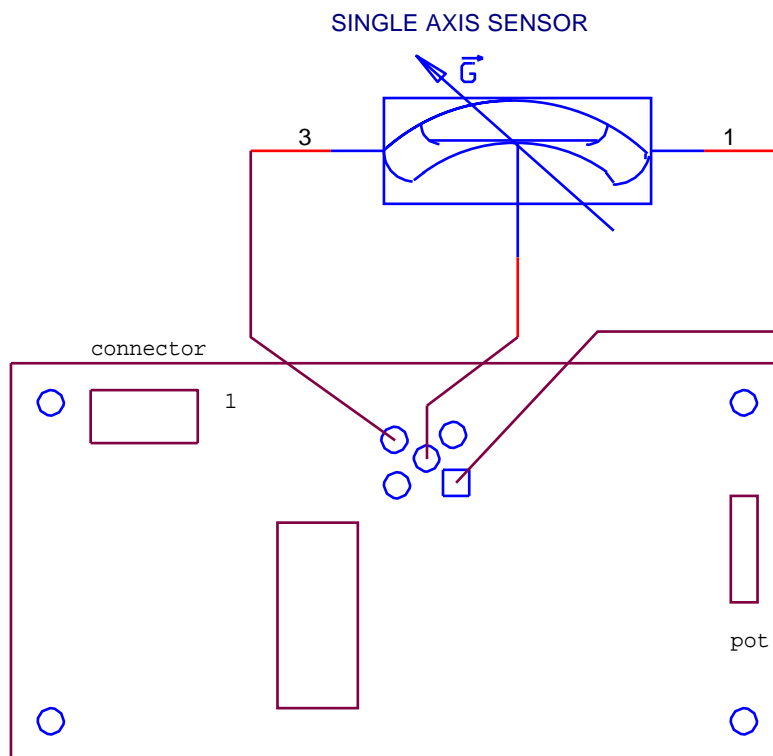

駿融企業有限公司 JIN ZON ENTERPRISE CO., LTD.
104 台北市長安東路二段 171 號 4 樓之 3
4F-3, No. 171, Sec. 2, Chang An E. Rd., Taipei, Taiwan, R. O. C.
TEL: 886-2-27111093~5 FAX: 886-2-27310902
E-mail: jinzon@ms2.hinet.net Http:// www.jinzon.com.tw/

Application Note

SSY0135 - RS232 (MICRO-50) Signal Conditioner Operating Instructions

Input/Output Connections

Circuit Board Connector - JP3	Function	corresponding PC Serial port connection *
PIN#		PIN#
1	Input Voltage = +7 to +12Vdc	none
2	Ground	5
3	Output Data	2
4	Input Command	3

* A DB9 type connector is required to connect to the PC serial port (not supplied)

Communication Protocol

All functions are available in the single axis configuration. The serial port is setup for the following protocol.

RS232C

Baudrate 19200
Data width 8 bits
Stop bit 1
Parity none
Flow Control none

Commands

All the commands have to be sent in the upper case mode in ASCII format.

A Reset board
B Read Pitch (not used in single axis configuration)
C Read Roll
D Read Temperature
E Reserved
F Stores offset for the roll and pitch
G Reserved
H Send calibration data
I Turn off excitation

When the **A** command is sent to the SSY0135, it resets itself, and sends back the ASCII character 'R' when it is ready to accept a new command.

駿融企業有限公司 JIN ZON ENTERPRISE CO., LTD.
104 台北市長安東路二段 171 號 4 樓之 3
4F-3, No. 171, Sec. 2, Chang An E. Rd., Taipei, Taiwan, R. O. C.
TEL: 886-2-27111093~5 FAX: 886-2-27310902
E-mail: jinzon@ms2.hinet.net Http:// www.jinzon.com.tw/

Application Note

SSY0135 - RS232 (MICRO-50) Signal Conditioner Operating Instructions

B and **C** command will be followed by 4 bytes. The first 3 bytes will be ASCII characters, representing the angle in Hexadecimal (to translate into an angle see the calibration sheet). The last byte is the Line Feed 10 (A in hexadecimal).

When **F** is received the unit turns off the sensor excitation. It stores the next 4 characters (ASCII format) as an offset for pitch axis (not used in single axis configuration), and then stores the next four characters for the roll axis. The values are stored in the nonvolatile memory of the microcontroller in hexadecimal format. Once the microcontroller has stored the values in its memory, it restarts the excitation and sends **.R.** to the host. It will take 20 seconds to read a stable output from the time the excitation is turned back on. This is equivalent to turning the unit power on.

The microcontroller will do a two's complement addition with the reading from the analog to digital converter. It should be noted that when the offset is added to the result of the analog to digital converter the output on the end of the scale can change the sign.

H tells the signal conditioner to send to the host, in the following order, the pitch offset, the roll offset and the temperature coefficient. The temperature coefficient is set to 1 and is reserved for future extensions.

I command turns off the excitation to the microcontroller. This allows the user to save power. It will take 20 seconds for the measurement to be stable once the excitation is turned on. The excitation is turned back on when the microprocessor is reset with the command **A** or the power is turned off and on.

D command will connect the output of the temperature sensor to the amplifier's input. The SSY0135 will send the data with the same format as for the pitch and roll. The gain adjustment does not affect the temperature measurement. The scale factor is 1 counts per Degree Celsius (160 (0A0Hex) AT 25).

Circuit Block Diagram

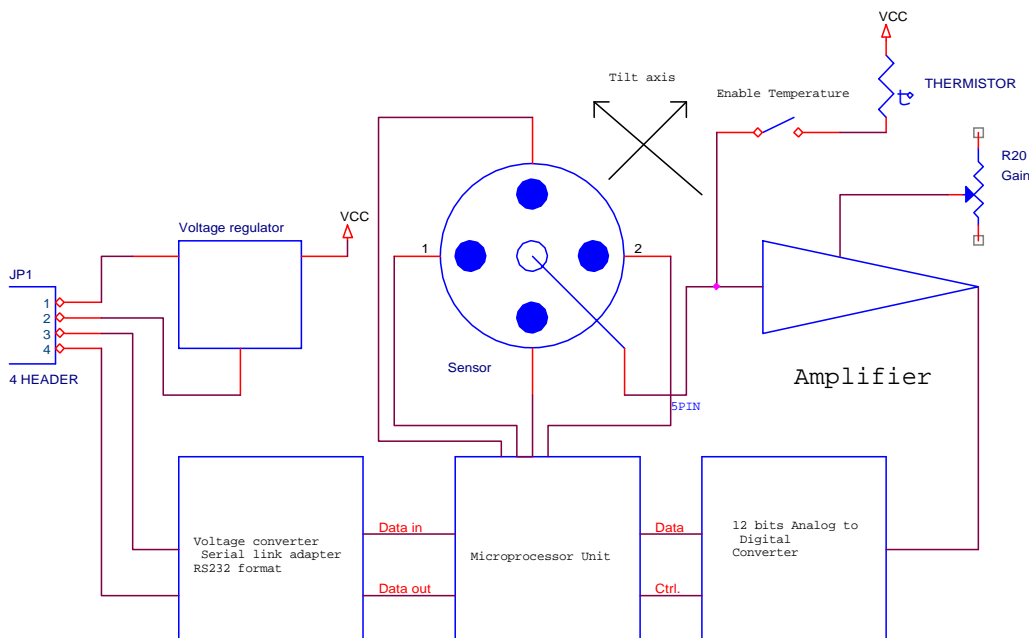

駿融企業有限公司 JIN ZON ENTERPRISE CO., LTD.

104 台北市長安東路二段 171 號 4 樓之 3

4F-3, No. 171, Sec. 2, Chang An E. Rd., Taipei, Taiwan, R. O. C.

TEL: 886-2-27111093~5

FAX: 886-2-27310902

E-mail: jinzon@ms2.hinet.net

Http:// www.jinzon.com.tw/

Application Note

SSY0135 - RS232 (MICRO-50) Signal Conditioner Operating Instructions

Connecting to a PC

The output of the MICRO-50 can be read directly with a PC by using Hyper-terminal. Setup Hyper-terminal the following way. HyperTerminal is located in the folder Programs\Accessories\Communications. The setup is found in the menu File → Properties.

In the window "Connect using", select the serial port the MICRO-50 is attached to. Press the button to configure.

Setup as follows:

bits per second = 19200

data bits = 8

parity = none

stop bits = 1

Flow control = none

The output of the SSY0135 is ASCII characters, in Hexadecimal format (see *COMMANDS* above).

Example

For instance at 0 degree tilt the output of the unit is 800(HEX). To convert it in decimal use this equation:

First byte * 16² + Second byte * 16 + third byte

8*16² + 0*16 + 0 = 2048

If the unit is tilted and the output is A11 the conversion in decimal is :

(10) A*16² + 1*16 + 1 = 2577

The output can be converted to an angle the following way :

(2577-2048)* (the scale factor provided with the unit calibration sheet).

To linearize the SSY0135 for a dual axis sensor type SP50XX, use the following characteristic equation:

Coeff3 X output³ + Coeff2 X output² + Coeff1 X output

The following are the coefficients:

60 degrees angle

Coeff1 = 0.0468

Coeff2 = 0

Coeff3 = -0.000000004

45 degrees angle

Coeff1 = 0.03125

Coeff2 = 0

Coeff3 = -0.000000002

20 degrees angle

Coeff1 = 0.0129

Coeff2 = 0

Coeff3 = -0.0000000003

The output when the sensor is at 0 degrees is 2048. 2048 should be subtracted from the output before applying the equation.

駿融企業有限公司 JIN ZON ENTERPRISE CO., LTD.

104 台北市長安東路二段 171 號 4 樓之 3

4F-3, No. 171, Sec. 2, Chang An E. Rd., Taipei, Taiwan, R. O. C.

TEL: 886-2-27111093~5

FAX: 886-2-27310902

E-mail: jinzon@ms2.hinet.net

Http:// www.jinzon.com.tw/

Application Note

SSY0135 - RS232 (MICRO-50) Signal Conditioner Operating Instructions

駿融企業有限公司 JIN ZON ENTERPRISE CO., LTD.
104 台北市長安東路二段 171 號 4 樓之 3
4F-3, No. 171, Sec. 2, Chang An E. Rd., Taipei, Taiwan, R. O. C.
TEL: 886-2-27111093~5 FAX: 886-2-27310902
E-mail: jinzon@ms2.hinet.net Http:// www.jinzon.com.tw/